

light-tec
be bright. save energy.



CAMPANA HB 100W

Avenida Ferrocarril (Atanasio Tzul) 19-97 Zona 12
Centro Empresarial El Cortijo 1, Bodega #206 Guatemala Guatemala
Telefono: (+502) 2462-6420/21

www.light-tec.com.gt

CAMPANA

ADVANTAGES

- Unique flat wheel form design
- Die-casting integrated AL casing make faster heat dissipation
- Optical glass over 90% light transmitting
- LED 3030 chip with low lumen decay
- IP65 driver with short circuit/over-flow/over-temperature/over-voltage protection
- 150lm/W, over 90% energy saving
- Lifespan 50,000 hours, 36 months warranty from its date of manufacture
- Easy installation and low maintenance
- Type of driver: Insulated driver

FUNCTION AVAILABLE

- Reflector for high-bay is available(Material for reflector: PC or Aluminum)



PRODUCT SIZE

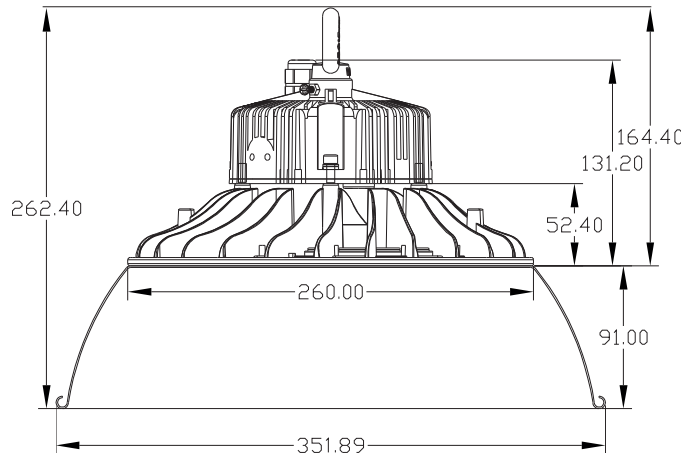

100W(AL reflector)

SPECIFICATIONS

Input voltage	AC100-277V
Power	100W
Dimming	Not
PF	>0.95
LED Type	3030
Beam angle	120°
Light efficiency	150 lm/W
luminous	15000 lm
Color Temp	3000" 200K / 4000" 250K / 5700" 300K / 6500" 500 K
CRI	>70
IP	IP65
Working Temp	-20!C~45!C
Storage Temp	-40!C~60!C
Life span	50000h@25!C

PACKAGE

QTY/Carton	1 pcs
Carton Size	310*310*192mm
N.W	2 .0KG
G.W	2.8 KG

CERTIFICATE



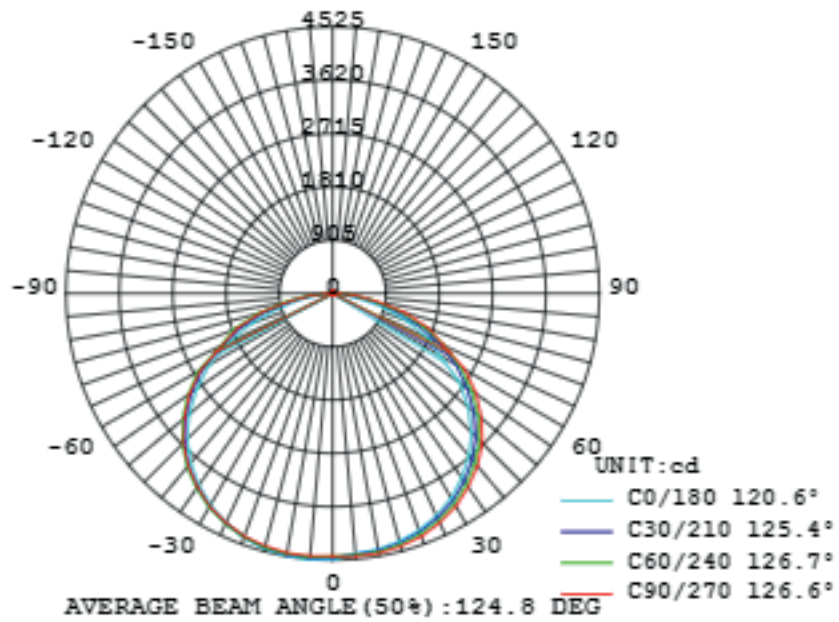

LUMINOUS INTENSITY DISTRIBUTION

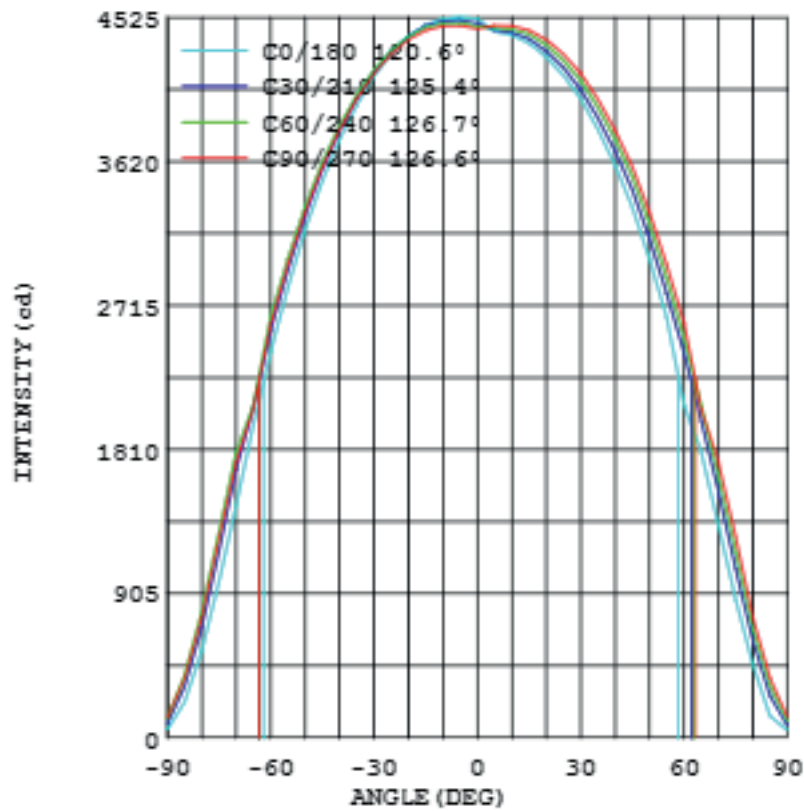

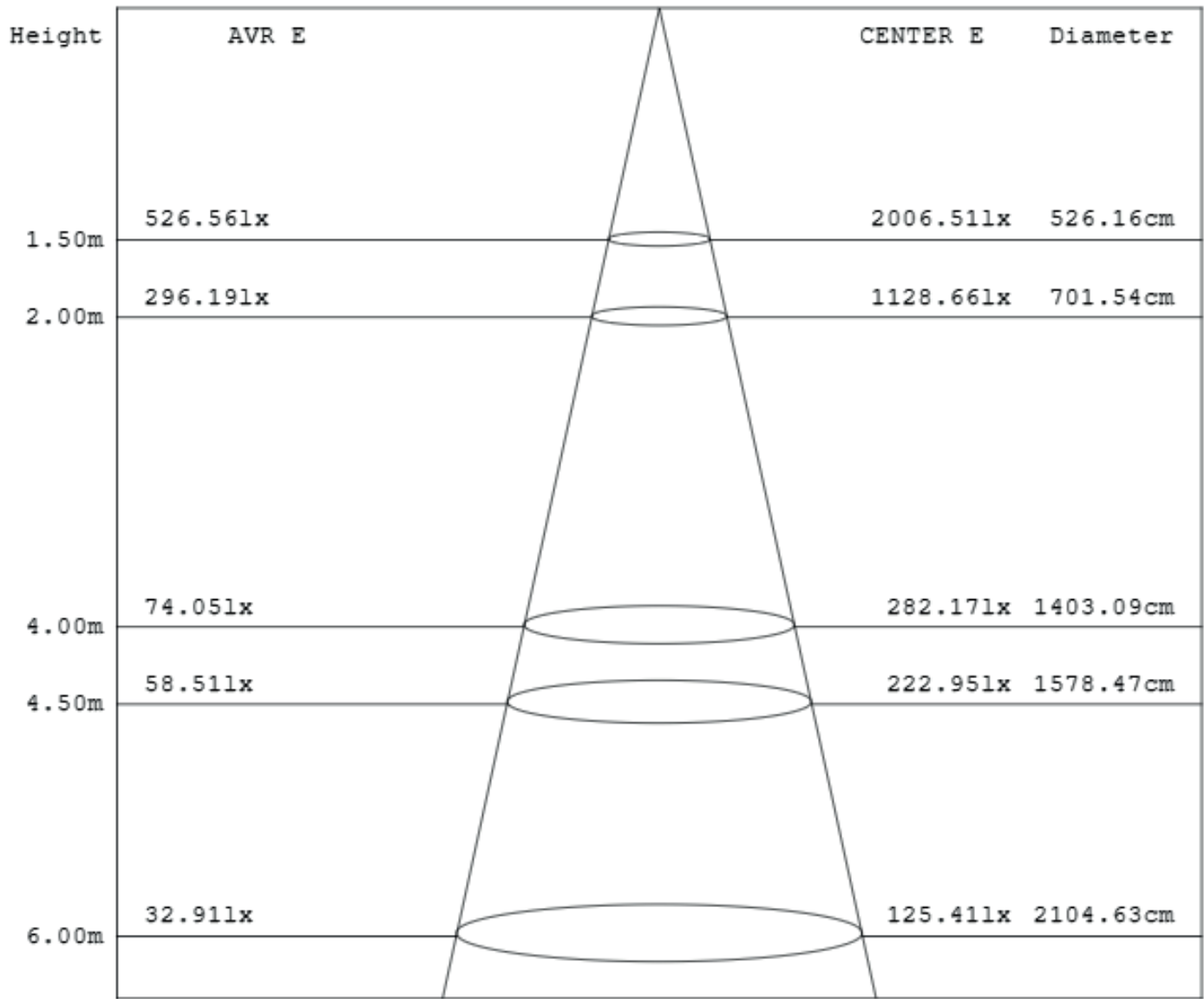

Angle: 120.6deg